

# CPS<sup>®</sup>

## OIL-LESS REFRIGERANT RECOVERY SYSTEM



MODEL  
**CR500**  
SERIES

**TO BE OPERATED BY  
QUALIFIED  
PERSONNEL ONLY!**

**This equipment has been certified by Underwriter Laboratories (UL) to meet or exceed EPA regulations per ARI 740-95 for refrigerants 12, 134a, 22, 500 and 502. See Specifications for a complete list of refrigerants**

# OPERATION MANUAL

# TABLE OF CONTENTS

INTRODUCTION .....	2
GENERAL SAFETY INSTRUCTIONS .....	3
SPECIFICATIONS .....	4
DIRECT LIQUID OR VAPOR RECOVERY .....	5
LIQUID PUSH-PULL RECOVERY .....	5
ROUTINE MAINTENANCE .....	6
TROUBLE SHOOTING CHART .....	7
HELPFUL HINTS .....	7
WARRANTY & CONTACT INFORMATION .....	8

## INTRODUCTION

Thank you for purchasing the **CPS® PRO-SET® CR500** refrigerant recovery machine. Like any CPS® product, the CR500 series machines combine the latest in product technology with the practical “hands on” features that our customers actively request. Focusing on product performance, recovery speed and reliability, we were able to develop **the most advanced oil-less recovery machines on the market today!**

Designed to service commercial/residential refrigeration and air-conditioning systems, the PRO-SET® CR500 is the lightest most compact refrigerant recovery machine in its class. A convenient “**QUICK START GUIDE**” is permanently attached to the side of the unit and acts as a quick and easy reference for the proper operation of the unit. Once the recovery is complete, simply turn the center valve to the **SELF-CLEARING** position to automatically remove any residual refrigerant left in the machine. The unit is now ready to recover the next refrigerant type.

The PRO-SET® CR500 series utilizes a 1/3hp/0.75kW oil-less compressor, non-restrictive manifold valves and a high efficiency rifle-fin condenser/evaporator combination for quick and easy refrigerant recovery.

Additional features include:

- **EXTREMELY LIGHTWEIGHT:** unit weighs less than 20 lbs/9.1 kg
- **HIGH PERFORMANCE** integrated fan
- “**ON THE RUN**” **SELF-CLEARING VALVE:** No need to turn the unit off when switching from recovery to self-clearing.
- **BUILT-IN FILTER:** located under intake port. No dangling filters to damage.
- **FILTER CARTRIDGE** can be easily cleaned or replaced
- **R-410A COMPATIBLE:** Special high-pressure unit design with extended pressure gauge ranges.
- **HIGH EFFICIENCY** rifle-fin condenser/evaporator
- **INTEGRATED MANIFOLD BLOCK BODY**
- **On Board** suction and discharge gauges
- **INDESTRUCTIBLE** high density polyethylene case
- **HEAVY DUTY** powder coated aluminum chassis
- **COMFORTABLE** integrated carrying handle
- **550 psig** High-pressure cutout
- **MAINTENANCE FREE** oil-less compressor
- **OPTIONAL TANK OVERFILL SENSOR** cord kit

To help you get a good start, please continue to read the balance of this manual. It contains important information on the operation, maintenance and safety issues you should thoroughly understand before attempting to operate the CR500 series machine. We recommend that you pay close attention to the safety information, **WARNINGS** and **CAUTIONS** located throughout this manual. Always remember, “Safety First.”

## UNIT CONSIST OF:

•PRO-SET® model CR500 • Power Cord Set (110 volt version only) • Operation Manual •



## GENERAL SAFETY INSTRUCTIONS

**ONLY QUALIFIED SERVICE PERSONNEL SHOULD OPERATE THIS UNIT. MOST STATES, COUNTRIES, ETC... MAY REQUIRE THE USER TO BE LICENSED. PLEASE CHECK WITH YOUR LOCAL GOVERNMENT AGENCY.**

**DANGER** - the recovery tank contains liquid refrigerant. Overfilling of the recovery tank may cause a violent explosion resulting in severe injury or even death. As a minimum use a scale to continuously monitor the recovery tank weight.

**DANGER** - Avoid breathing refrigerant vapors and lubricant vapor or mist. Breathing high concentration levels may cause heart arrhythmia, loss of consciousness, or even cause suffocation.

**DANGER** - ELECTRICAL SHOCK HAZARD - **Always disconnect power source when servicing this equipment.**

**DANGER** - EXPLOSION RISK. Do not recover flammable refrigerants.

**CAUTION** - all hoses may contain liquid refrigerant under pressure. Contact with refrigerant may cause frostbite or other related injuries. Wear proper personal protective equipment such as safety goggles and gloves. When disconnecting any hose, please use extreme caution.

**CAUTION** - avoid breathing refrigerant vapors and/or lubricant mist. Exposure may irritate eyes, nose, throat, and skin. Please read the manufacturers Material Safety Data Sheet for further safety information on refrigerants and lubricants.

**CAUTION** - to reduce the risk of fire, avoid the use of extension cords thinner than NO. 14 awg. (1,5mm<sup>2</sup>) to prevent the overheating of this cord please keep length to a minimum.

**CAUTION** - do not use this equipment in the vicinity of spilled or open containers of gasoline or other flammable substances. Make certain that all safety devices are functioning properly before operating the equipment.

This equipment is intended for use of one refrigerant at a time until the SELF-CLEARING feature is used. Mixing of different refrigerants will cause your recovered supply of refrigerant to become contaminated. NOTE: It is very expensive to destroy mixed or damaged refrigerants.



## CR500 SERIES SPECIFICATIONS

	CR500	CR500J	CR500S
Compressor Type	1/3 HP Oil-less Reciprocating Compressor		
Dimensions	20cm (8") wide x 37cm (14.5") long x 30.5cm (12") high		
Weight	9.1 kg (20 lbs.)		
Operating Temperature Range	0°C (32°F) to 49°C (120°F)		
Power Source	115 VAC 50/60Hz 1Ph	100 VAC 50/60Hz 1Ph	220-240 VAC 50/60Hz 1Ph
Power Consumption	500 W		
Suction Pressure Gauge	-30"hg vac to 500 psig	-0.1 -3.5 mPa	-30"hg vac to 500psig
Discharge Pressure Gauge	0 to 800 psig	0 -5.5 mPa	0 to 800 psig
Filtration	Cleanable 100-mesh screen integrated into Suction Port		
Shut-off Valves	Both Suction and Discharge manifold ball valves		
Construction	Heavy gauge aluminum chassis with High Density Polyethylene Case		
Overload Protection	10A thermal circuit breaker	550 psig	5A thermal circuit breaker
High Pressure Shut-off			
Refrigerants	R-12, R-134a, R-401C, R-406A, R-500, R-401A R-409A, R-401B, R-412A, R-411A, R-407D, R-22 R-411B, R-502, R-407C, R-402B, R408A, R-509 R-407A, R-404A, R-402A, R-507, R-407B, R-410A		
Direct Vapor	Flow Rate Up to 1.00 lb./min		
Direct Liquid	Up to 2.50 lb./min		
Push-Pull Liquid	Up to 11.00 lb./min		

## DIRECT VAPOR OR LIQUID RECOVERY OPERATION

1. Connect the unit as shown in Diagram 1.
2. Open the vapor valve on the Recovery Tank.
3. Open **DISCHARGE** valve on CR unit.
4. Rotate the center valve to the “**RECOVERY**” position.
5. Turn power switch to “ON” position.

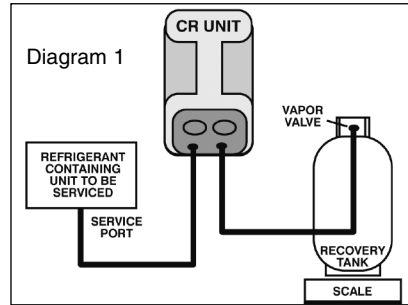

6. Once unit has started, open the **SUCTION** valve on the CR unit to start the refrigerant flow.  
NOTE: If liquid refrigerant is present, a hammering sound will come from the compressor. Use the **SUCTION** valve to meter or regulate the incoming refrigerant until the hammering sound goes away. The **SUCTION** gauge will read the regulated pressure to the compressor.
  7. Monitor the suction gauge until it falls below the required vacuum level.
  8. Rotate the center valve to the **SELF-CLEARING** position. Again monitor suction gauge. Once the gauge reads a vacuum, Close **SUCTION** valve, turn unit OFF.
- **RECOVERY AND SELF-CLEARING ARE COMPLETE.**

## PUSH-PULL LIQUID RECOVERY OPERATION

1. Connect the unit as shown in Diagram2.
2. Open both valves on the Recovery Tank.
3. Open **DISCHARGE** valve on CR unit.
4. Rotate the center valve to the “**SELF-CLEARING**” position.
5. Turn power switch “ON” position.

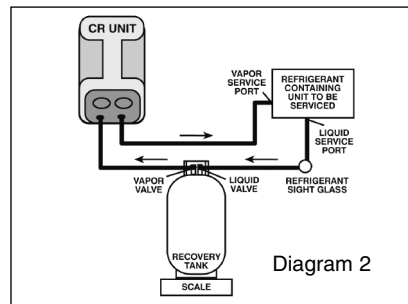

6. Once unit has started, open the **SUCTION** valve on the CR unit to start the refrigerant flow.
  7. Monitor the optional inline sight glass for liquid refrigerant movement.
  8. Once liquid refrigerant is no longer present, close recovery tank vapor valve. When the **SUCTION** gauge falls into a vacuum close **SUCTION** valve and turn unit OFF.
- **PROCEED TO DIRECT VAPOR RECOVERY OPERATION.**

## ROUTINE MAINTENANCE

**FILTER MAINTENANCE** - the CR SERIES is equipped with a 100 mesh screen filter. This filter should be checked periodically. A partially clogged filter will slow down the recovery rate of this unit.

**Replace the filter cartridge as follows:**

1. Use a 7/8" socket or boxed end wrench to loosen the suction port as shown in Figure 1.
2. Once loose, remove the suction port- filter cartridge assembly is shown in Figure 2.
3. Either clean the current cartridge or replace with new cartridge. (Item NO. CRXF3)
4. Inspect O-RING. RE-LUBRICATE with compressor oil or equivalent.
5. Place filter back into suction port fitting.
6. Hand tighten this assembly back onto the CR unit.
7. Use a 7/8" socket or boxed end wrench to tighten 1/8 of a turn. DO NOT OVER TIGHTEN, damage to the O-RING may occur.
8. Check the connection for leaks.



Figure 1



Figure 2

## TROUBLE SHOOTING CHART

**PROBLEM: The unit will only pull down to 0 pressure or a slight vacuum.**

**SOLUTION:** Remove refrigerant hose from Suction port. Place a cap on this port:

1. If the unit pulls a vacuum, then the low side leak is somewhere between the refrigerant hose and the equipment being recovered.
2. If the unit does not pull a vacuum, then suspect an internal low side leak on the CR unit.

---

**PROBLEM: The unit starts for a few minutes, then shuts-off.**

**SOLUTION:** The high pressure switch has activated. Make sure the discharge valve is open. Make sure the recovery tank valve(s) are open. Check for any other restrictions on the discharge port of the unit. Correct restriction. Restart the unit.

---

**PROBLEM: The unit does not start and the thermal circuit breaker activates.**

**SOLUTION:** If the unit fails to start, open the suction valve and rotate the center valve to the “**SELF-CLEARING**” position for 5-10 seconds. Then rotate back to the “**RECOVERY**” position. Reset circuit breaker. Push the **START** switch.

---

**PROBLEM: The unit recovers at a very slow pace.**

**SOLUTION:** Check the suction port filter. Replace or clean.

---

## HELPFUL HINTS

- If the refrigerant to be recovered is from equipment with high contamination levels of acid, moisture, etc.... it is recommended to utilize an in-line filter drier placed before the suction port of the CR600 unit. An Alco EKO52 or equivalent filter drier would provide adequate protection.
- If large amount of liquid refrigerant (greater than 70lbs.) are present, it would be recommended that Liquid Push-Pull method be performed first, then follow by Direct liquid or vapor recovery.
- A ball valve or an anti-blow fitting should be used on the end of the discharge hose. This will prevent unnecessary loss of recovered refrigerant. It will also protect the user from liquid refrigerant contact. Read General Safety instructions on refrigerant contact.
- When recovering refrigerant under low ambient temperature conditions, add heat devices such as receivers, accumulators, etc.... to help vaporize the refrigerant. This will greatly speed up the recovery process.

## WARRANTY & REPAIR POLICY

CPS® Products, INC. guarantees that all products are free of manufacturing and material defects for one year. If the equipment should fail during the guarantee period it will be repaired or replaced (at our option) at no charge. This guarantee does not apply to equipment that have been altered, misused, or returned solely in need of field service maintenance. This repair policy does not include equipment that is determined to be beyond economical repair. All products being returned for warranty repair must be accompanied by an original bill of sale and customer contact information.



# CPS®

CPS Products, Inc.  
1010 East 31st Street Hialeah, Florida 33013, USA  
TEL: 1-800-277-3808 (US only), 305-687-4121;  
FAX: 305-687-3743  
www.cpsproducts.com  
e-mail: cpssales@cpsproducts.com

CPS Products N.V.  
Krijgsbaan 241, 2070 Zwijndrecht, Antwerpen, Belgium  
TEL: (323) 281-3040; FAX: (323) 281-6583  
e-mail: info@cpsproducts.be

CPS Australia PTY. LTD.  
109 Welland Avenue, Welland, Sth Australia 5007  
TEL: +61 8 8340 7055, Fax: +61 8 8340 7033  
e-mail: sales@cpsaustralia.com.au

CPS Asia  
Ruby Industrial Complex #05-09A Genting Block 80 Genting Lane,  
Singapore 349565  
TEL: (65) 68461056, Fax (65) 68461057  
e-mail: cpsasia@signet.com.sg

#73-023 RevB