

ASTR®

Refrigeration Technology

ASTR Refrigeration Technology incorporates the latest Danfoss Scroll compressor technology in their new range of packaged refrigeration units called "The Commercial Range"



The Commercial Range

Features & Benefits:

- **Wide Temperature Range**
- **Danfoss Scroll Compressor**
- **Saginomiya Fan Speed Controller**
- **Airmender Oil Separator**
- **Accumulator**
- **Danfoss Dual Pressure Control**
- **Drier, Sight Glass**
- **Oil Filled Guages**
- **Nitrogen Holding Charge**
- **Gomax Flexible Hoses**
- **Passivated Fins**

R404A Refrigeration Capacity										Sound Power Level d B (A)	Sound Pressure 3m d B (A)	Sound Controlled 3m d B (A)
Model	Nominal H/P	SCT/ SST	LT		MT			HT				
			-25	-20	-15	-10	-5	0	5			
NF200D NF200S	2HP	32	2110	2565	3100	3665	4270	4905	5575	76	58	52
		38	1830	2285	2785	3310	3865	4445	5050			
		43	1535	2010	2520	3015	3525	4060	4620			
NF250D NF250S	2 1/2HP	32	2715	3413	4118	4740	5525	5442	7342	78	61	53
		38	2420	3110	3722	4330	5082	5894	6694			
		43	2153	2813	3421	3980	4714	5210	6014			
NF300D NF300S	3HP	32	3021	3945	4695	5515	6400	7360	8395	80	62	54
		38	2705	3625	4300	5045	5865	6755	7720			
		43	2490	3260	3975	4660	5420	6250	7165			
NF400S	4HP	32	4474	5375	6400	7525	8755	10085	11530	80	62	55
		38	4036	4910	5840	6880	8020	9275	10640			
		43	3364	4374	5375	6340	7410	8595	9895			
NF500S	5HP	32	5350	6685	7955	9350	10870	12515	14290	83	65	57
		38	4788	6120	7285	8570	9975	11510	13180			
		43	4320	5510	6720	7915	9235	10675	12250			
NF600S	6HP	32	6320	7890	9375	11005	12770	14685	16750	83	65	57
		38	5782	7230	8575	10060	11690	13470	15405			
		43	5390	6410	7905	9275	10795	12460	14285			

ASTR®

Refrigeration Technology

The company reserves the right to make specification changes without notice.

ASTR[®]

Refrigeration Technology

The Commercial Range

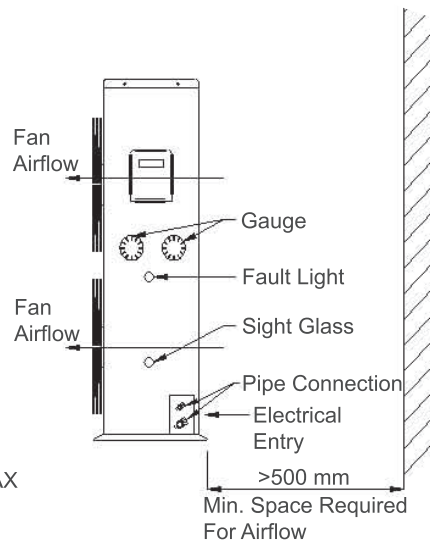
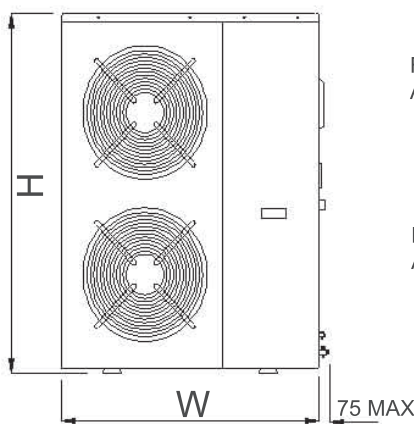
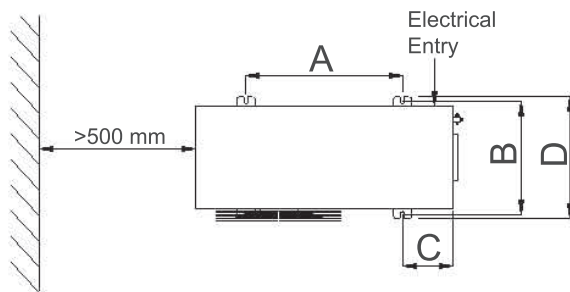

MODEL	COMP TYPE	NOM. HP	DIMENSIONS H (Height) x W (Width) x D (depth) mm	PIPE SIZE (INCH)	NETT KG	ELECTRICAL DATA	
						SUPPLY	FLA.
NF200D	MLZ015	2	H = 844 x W = 1104 x D = 578	3/8 3/4	79	230v-1ph-50hz	14
NF200S	MLZ015	2	H = 844 x W = 1104 x D = 578	3/8 3/4	79	400v-3ph-50hz	6.5
NF250D	MLZ019	2 1/2	H = 844 x W = 1104 x D = 578	3/8 3/4	83	230v-1ph-50hz	16.5
NF250S	MLZ019	2 1/2	H = 844 x W = 1104 x D = 578	3/8 3/4	83	400v-3ph-50hz	8
NF300D	MLZ021	3	H = 844 x W = 1104 x D = 578	3/8 3/4	86	230v-1ph-50hz	18
NF300S	MLZ021	3	H = 844 x W = 1104 x D = 578	3/8 3/4	86	400v-3ph-50hz	9
NF400S	MLZ030	4	H = 844 x W = 1104 x D = 578	1/2 3/4	86	400v-3ph-50hz	12.5
NF500S	MLZ038	5	H = 1244 x W = 1104 x D = 578	1/2 3/4	118	400v-3ph-50hz	15.5
NF600S	MLZ045	6	H = 1244 x W = 1104 x D = 578	1/2 3/4	118	400v-3ph-50hz	16